



- **Standard VoIP phone**
- **Robust housing, constructed of cold rolled steel with powder coat, with LCD display**
- **Vandal resistant handset and armored cord**
- **Full Rugged & durable keypad, easy to operate**
- **Wall mounting, simple installation**
- **Weather proof protection IP65**
- **4 additional buttons can programmable for auto-dial**
- **External Power supply or PoE (SIP phone)**
- **RJ45 port for SIP phone**
- **Inductive coupler fitted as standard for hard of hearing**
- **CE, FCC, RoHS, ISO9001 compliant**

The Handset Telephone is designed to meet the needs of client who experience loss through vandalism. Ideal for parking lots, prisons, railway/metro platforms, hospitals, police stations, ATM machines, bank foyer, stadiums, outside building etc.

Housed in cold rolled steel box and manufactured to a high standard, these telephones offer increased resistance to vandalism, and ensure that the primary function of communications is maintained at all times.

Extremely easy to install. The cable entrance is on the back of the phone to prevent from artificial damage, while the keypad is weather and vandal resistant.

SIP-VoIP TECHNICAL SPECIFICATIONS

Adapter Input:

100-240VAC 50~60Hz Output:5V/1A

Port:

WAN: 10/100Base- T RJ-45 for LAN, Auto MDIX

LAN: 10/100Base- T RJ-45 for PC, Auto MDIX

Power Consumption:

Idle:1.5W/ Active:1.8W

Main Chip: Broadcom

Voice Features

- Support 2 lines SIP, SIP 2.0 (RFC3261)
- Codec: G.711A/u, G.7231 high/low, G.729, G.722,G.726
- Echo cancellation: Support G.168 and hand-free can support 96ms
- Supports full duplex.
- SIP support SIP domain,SIP authentication(none, basic,MD5),DNS name of server, peer to peer
- SIP support 2 servers, user can through each server to calling in and out

Network Features

- WAN/LAN: support Bridge mode
- Support PPPoE for xDSL
- Support VLAN
- Support Stun penetration
- Support DHCP get IP on WAN port

TECHNICAL SPECIFICATIONS

Casing Material

Cold rolled steel body

Colors: Grey, Red, Blue or option

Handset Material

ABS material handset with stainless steel spiral cord.

Keypad

Weather sealed tactile digital keypad.
Chrome key and frame made of zinc alloy. Vandal resistance.

Temperature

Operating: -30°C to +65°C

Storing: -40°C to +75°C

Weather Resistance

IP65

Ringling Tone

Shrill warble tone 80 dBA @ 1 metre typical

Hook switch

Electronic / magnetic with no visible moving parts

M.T.B.F.

Calculated to have an M.T.B.F. in excess of 40,000 hours using

Weight

Up to 4 kg depending on option

DIMENSIONS:

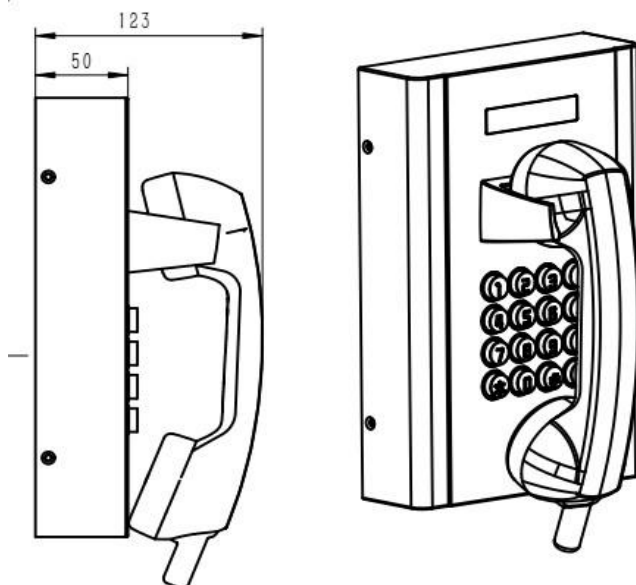
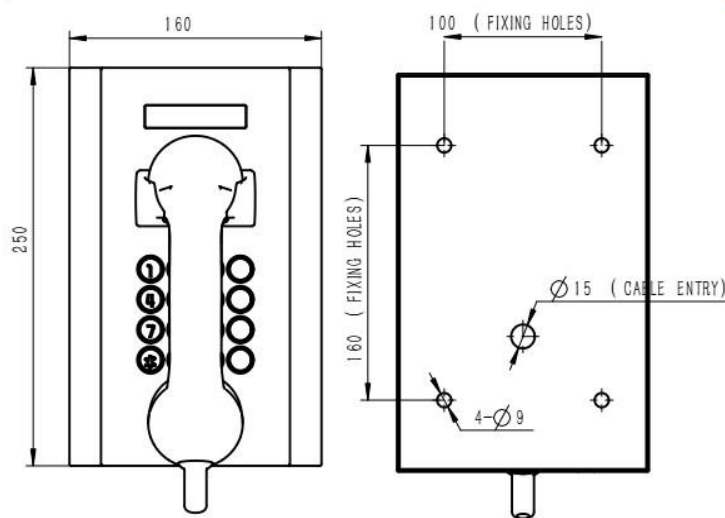

APPROVALS



This mark indicates compliance with the:
Radio & Telecommunications Terminal
Equipment Directive
2004/108/EC



This mark indicates compliance with the:
FCC Part 15 Subpart B Class B

Size of Display

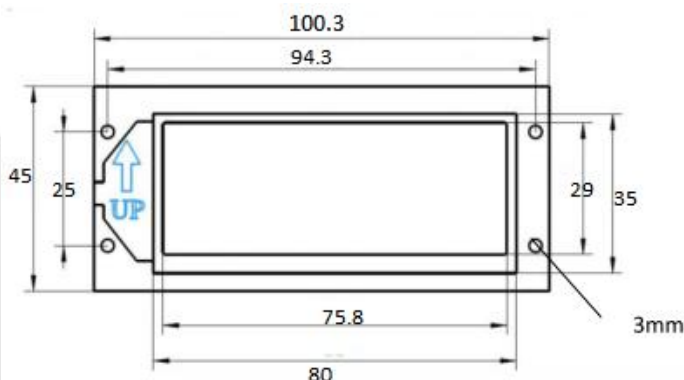

(Measured in mm)

PACKAGE

Unit size: 250 *160 *123 (mm)

Carton size: 340 *235 *165 (mm)

Packaging materials: Pearl cotton, Carton

Net weight: 3.5 KG

Gross weight: 4 KG